

DRAWING FOR CUSTOMER

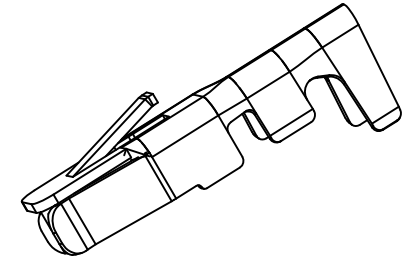

- SPEC.:
- Rated Voltage: 250V AC,DCm
 - Rated Current: 2A AC,DC
 - Withstand Voltage: 800V AC/minute
 - Contact Resistance: 20mΩ (MAX.)
 - Insulation Resistance: 1,000MΩ (MIN.)
 - Temperature Range: -25°C~+85°C

- Terminal:
- Material: Phosphor Bronze
 - Finish: Tin plated; over Nickel
 - Applicable wire: AWG#26-30

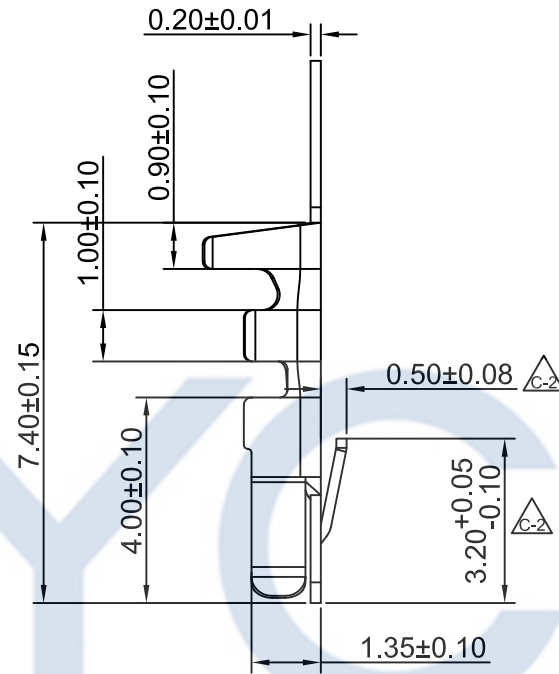
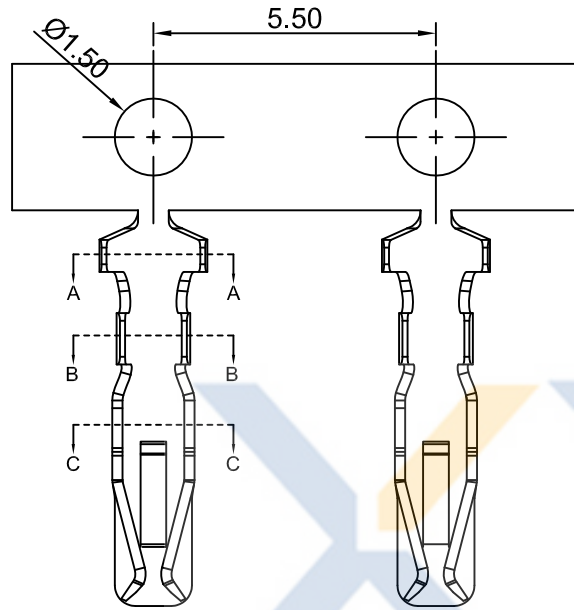
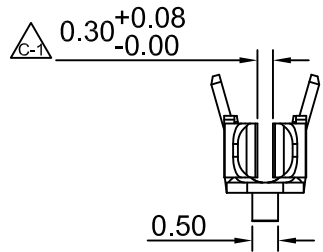

SECTION C-C

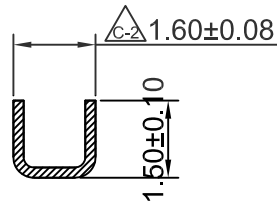

SECTION B-B

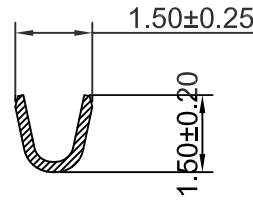

SECTION A-A

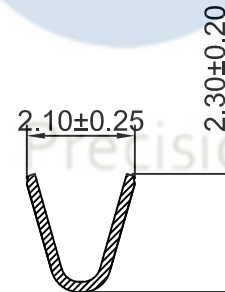

KB936-XXXT1C

- 1: All plating
2: Half plating
- Plating
- 0: Tin-plat
1: Gold Plat 1u"
2: Gold Plat 3u"
3: Gold Plat 5u"
- Version
Mold No.
Terminal

2021-04-05	C-2	调整尺寸, 优化产品	KB936-XXT1C	Devin
2020-02-22	C-1	优化产品	KB936-XXT1C	Devin
2014-09-19	A	新模发行	KB936-XXT1A	Devin
DATE 日期	VER 版本	CHANGE HISTORY 變更歷史	CHANGED NAME 修改後料號	DRAWING 變更者

TOLERANCE 公差	DRAWING 設計者	Devin	KB936-XXT1C	
.X=±0.30 .XX=±0.20 .XXX=±0.10	CHECKED 審查	Thomas	PART NO. 料號	
	APPROVED 核准	William	DWG NO. 圖號	PE3802A

XYCO 东莞市轩业电子科技有限公司
TEL: 0769-8297 9981/2/3 http://www.XYCO.com.cn

UNIT 單位	mm	PRODUCT NAME 產品名稱	PHB2.0mm Wire To Board Terminal
------------	----	----------------------	---------------------------------